

NOTES1:

UL Standard

1. Rated voltage/current : 150V / 10A

2. Withstanding voltage : AC1300V/1Min.

IEC Standard

1. Pollution degree	2
Overvoltage category	III
Rate impulse voltage(KV)	4KV
Rate voltage(V)	400V
Rate current(A)	32A

NOTES2:

1. Dimension shall be interpreted per

ASME Y14.5-2009

2. Pitch : 3.50mm, Poles : N=04~48P

3. Operating temperature: -40°C~+105°C

4. Undimensioned tolerances:

Pitch range in mm	Nominal dimension range in mm		-	∩	□	
	Over	Tolerance				Over
6	10	±0.10	30	±0.10	150	±0.10
10	10	±0.10	60	±0.10	100	±0.10
10	24	±0.30	100	±0.30	150	±0.30
10	30	±0.30	60	±0.50	100	±1.00
10	30	±0.30	100	±0.70	150	±1.30

5. RoHS Compliance

Ordering Information

JL15EDGVHDM-350 XX G 0 1

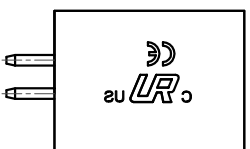
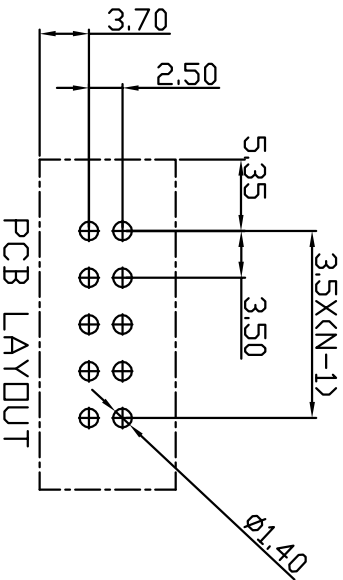
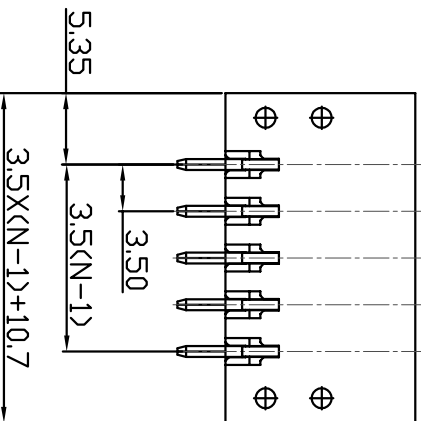
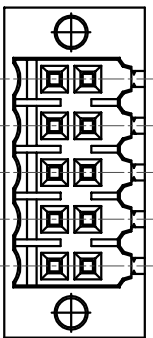
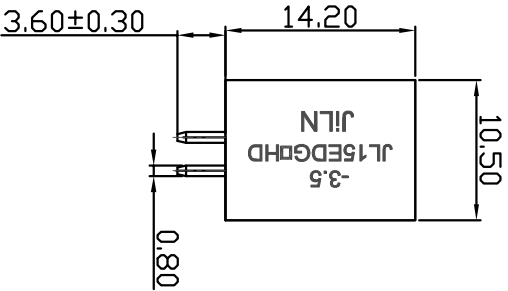
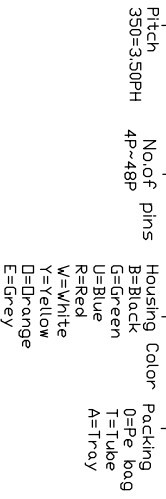

REVISION RECORD			
REV	ECN	DESCRIPTION	DATE
A0		NEW	21.04.24

DRAW	SHUANGPING ZHENG	SCALE	FIT	 东莞市锦凌电子有限公司 DONGGUAN JINLING ELECTRONIC CO., LTD
CHECK	LICHAD LIU	UNIT	mm	
APPROVE	YONGLIANG GAO	SIZE	A4	
		SHEET	1/1	PART NO.
		PRD		JL15EDGVHDM-350XXG01
				TITLE:
				JL15EDGVHDM-350-XXP 插拔式公座/绿色